



TABLE OF SPECIFICATIONS

Type of filter	TRIO-UV
Connection diameter	3/4" + 1"
Max. flow rate (m ³ /h) at temp. 30°C	2
Max. working pressure (bar)	16
Max. temperature	50°C
Weight (kg)	1,7
Water transmission (minimum %)	90
Lamp nominal power (W)	25 ±10%
Supply voltage	230 V Ac /50Hz

UV-2100
ø3/4" + 1"



info@cintropur.com - www.cintropur.com



IMPORTANT CAUTION

In order to guarantee that water is of drinkable quality, it must be chemically drinkable before being treated by UV.

The UV CINTROPUR is delivered with an ultraviolet bulb installed. The UV bulb is a low pressure, mercury-vapour bulb, emitting light on the germicidal wavelength of 253.7 nanometres.

To ensure maximum effectiveness of ultraviolet treatment, we always recommend placing a prefilter 25µ before UV.

If the water treatment system on your installation comprises several treatment units, the UV is always installed as the final unit.

The electrical connection is made via a three-pin plug with earth (ground). Before connecting the unit, check that the power supply corresponds to the 220 volts, 50 Hz needed by the unit.

For your safety: the power of the device must be fitted with a differential circuit breaker with a 30 mA sensibility. When the UV bulb is operating a blue light can be seen through the drain screw.

The sterilizer must always be left running, even if no water is being used. Nevertheless, in the event of a prolonged absence without any water being used (holidays, absence for longer than a week, etc.) the UV CINTROPUR should be switched off to avoid overheating of the bowl and the UV bulb.

When service is resumed, allow the water to run for approximately 1 minute (with the sterilizer switched on) before any is consumed.

Frequent Start/Stop operation or operation without any water in the bowl is not recommended since the lifespan of the UV bulb will be reduced.

The UV CINTROPUR must only operate with water temperatures between 5°C and 50°C; outside this range the unit may be damaged.

Do not expose your eyes or skin directly to the UV light of the sterilizer bulb. Maintenance is limited to changing the UV bulb once a year on the same date, and to cleaning the quartz sheath if necessary.

The new, UV bulb must be perfectly dry before it is fitted to the quartz sheath. Take great care to ensure that your fingers do not come into contact with the glass of the bulb.

The quartz sheath may clog up or show signs of traces of lime scale. Should this occur, the sheath must be removed and cleaned using dilute acid (hydrochloric acid, vinegar, lime scale solution). Any product that is used must not be abrasive.

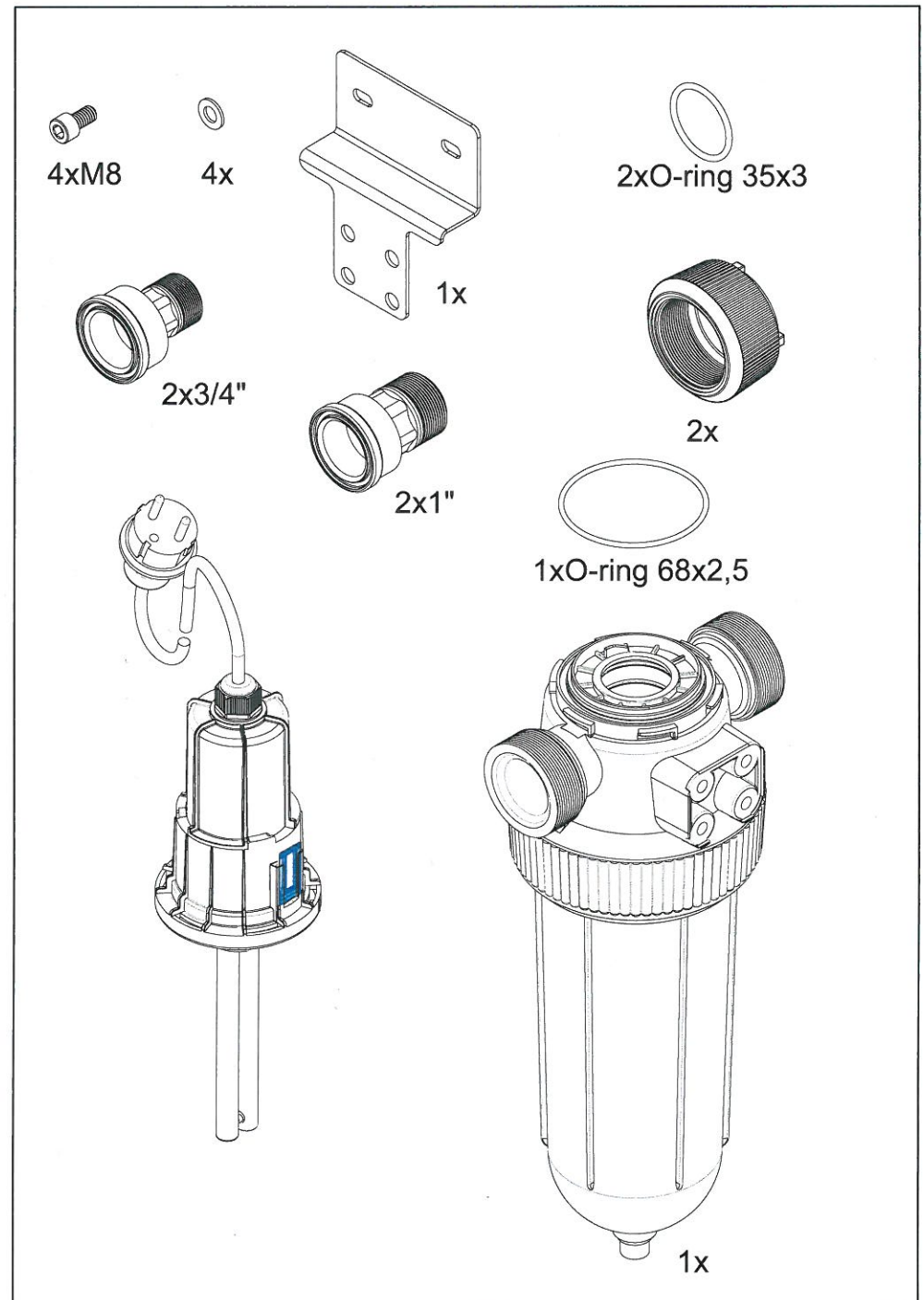

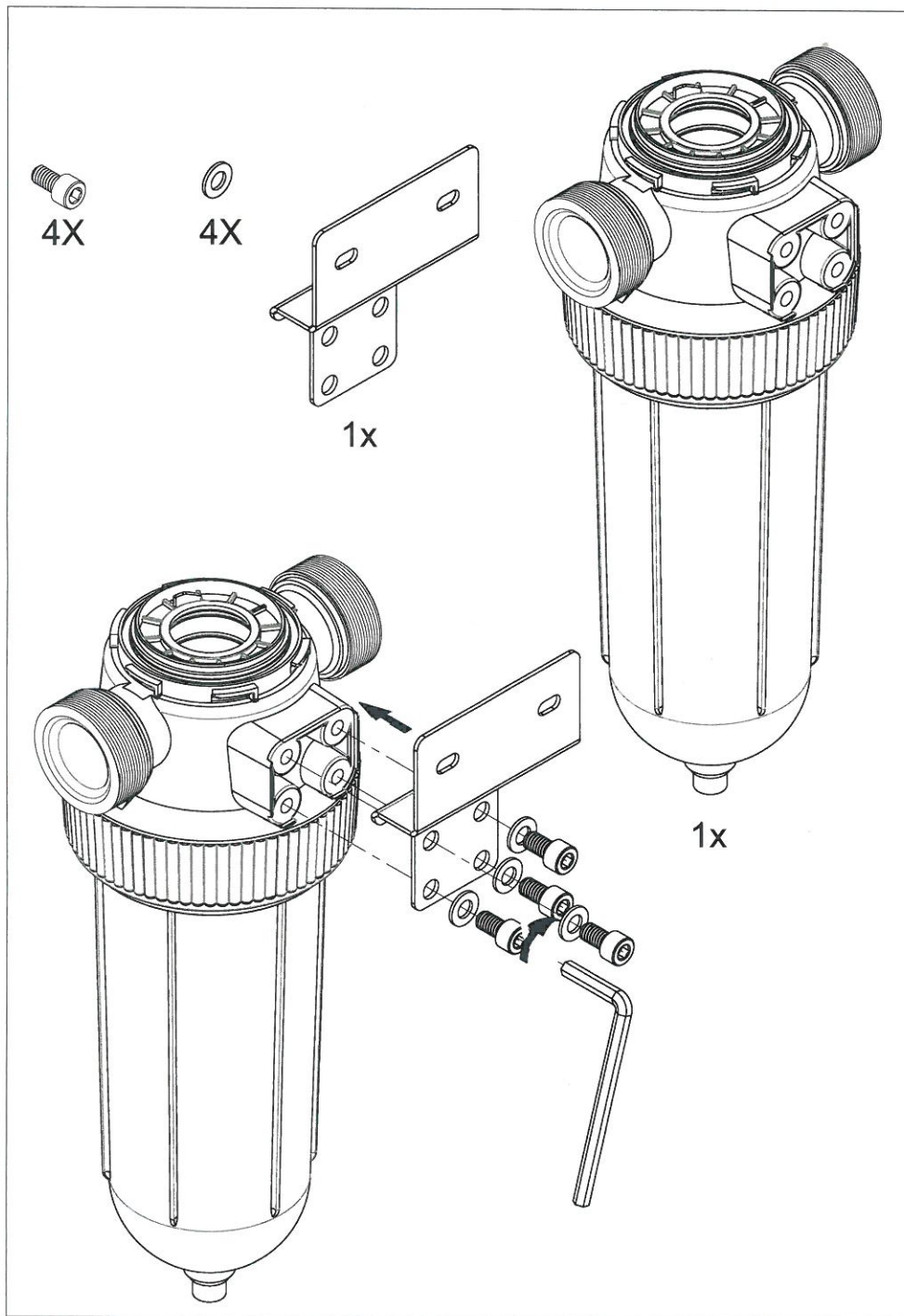

4

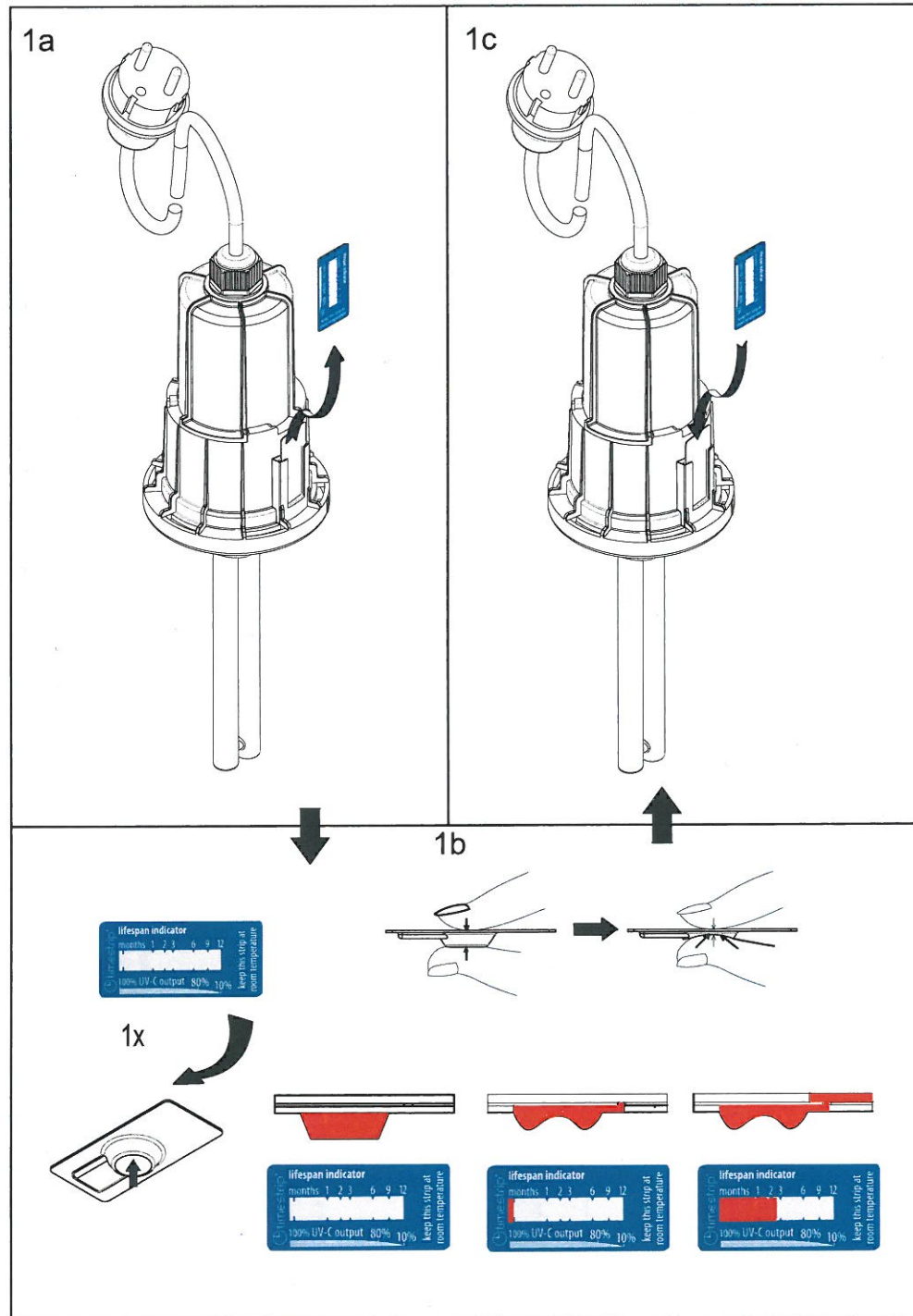

5

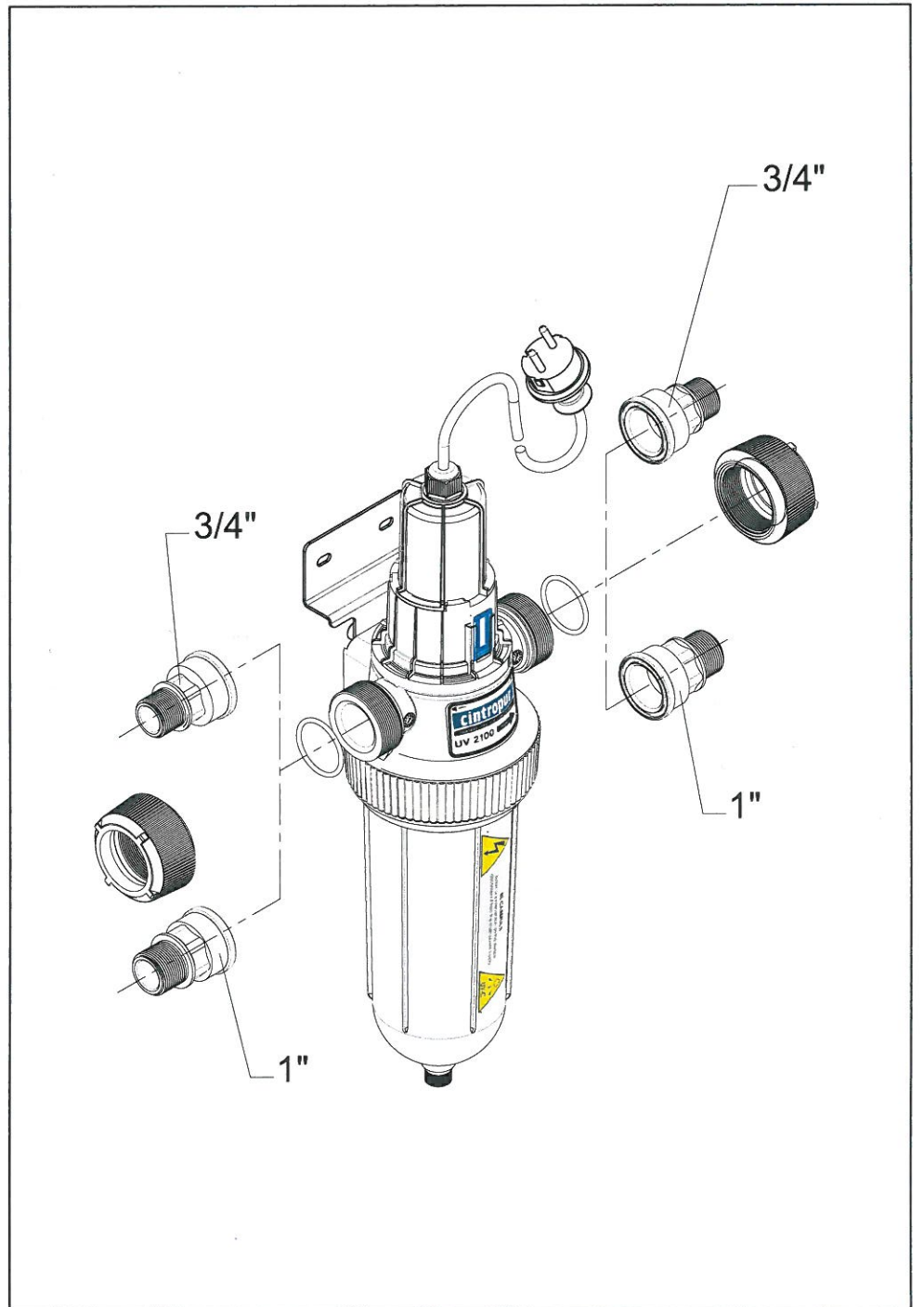
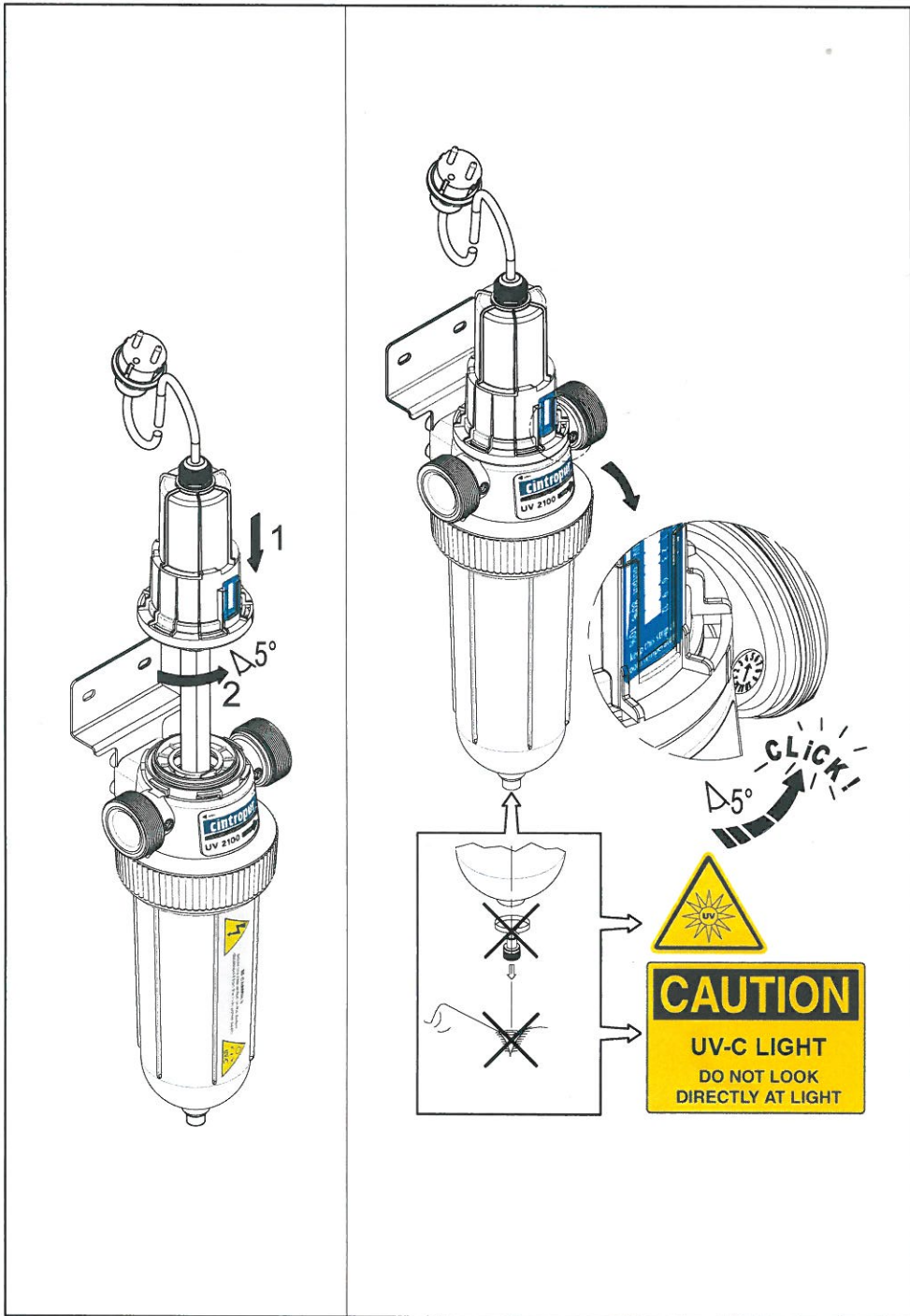

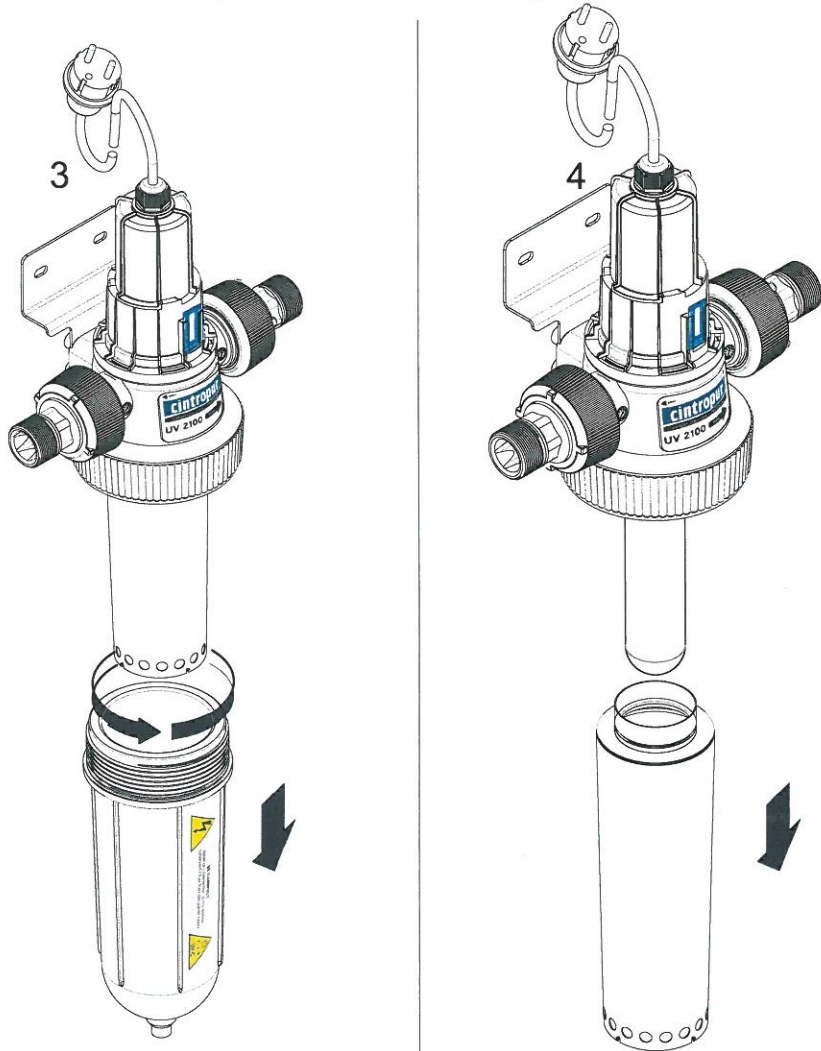
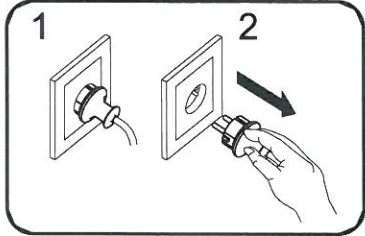

8

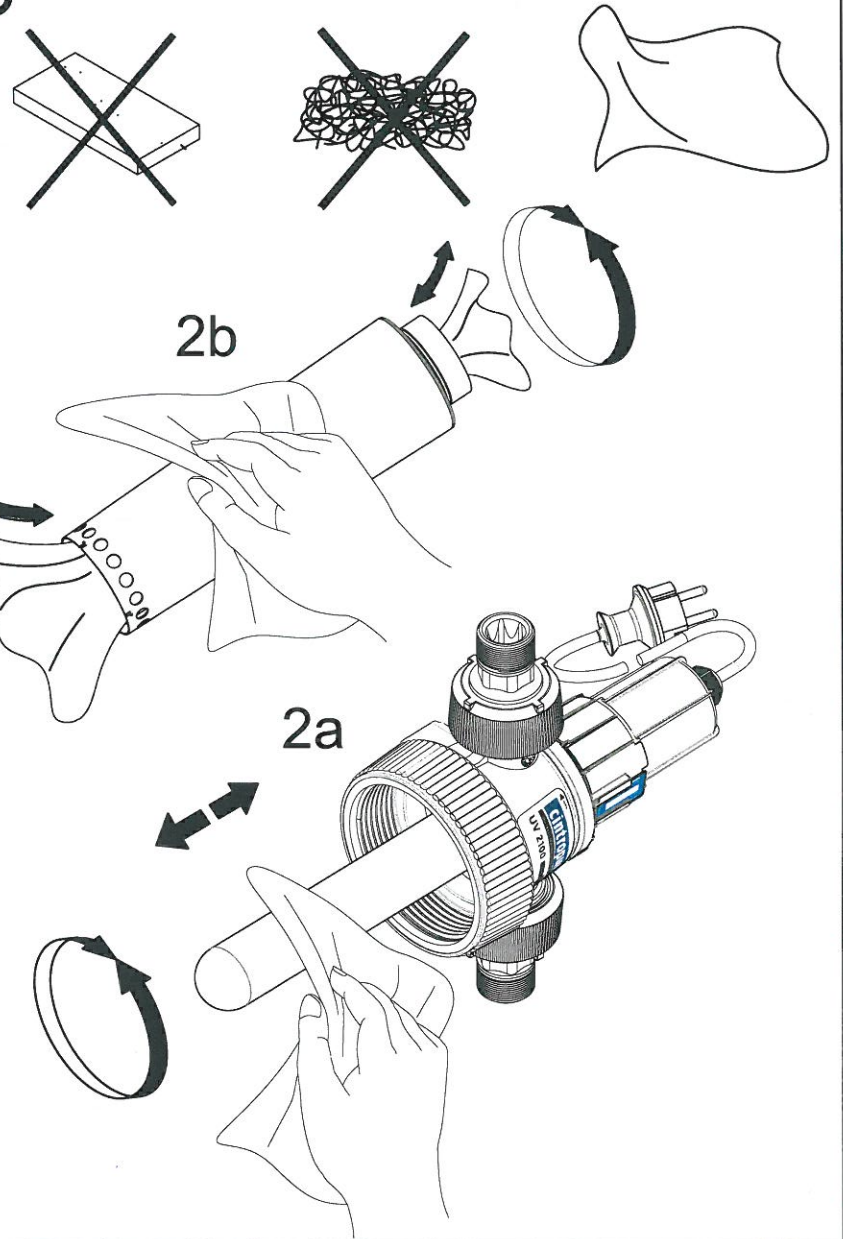

9

AFTER 1 YEAR OF USE

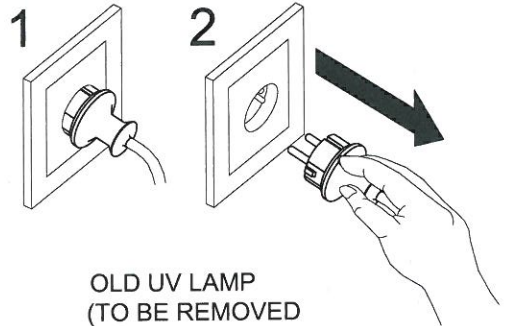

OLD UV LAMP
(TO BE REMOVED
AND REPLACED BY
A NEW ONE)

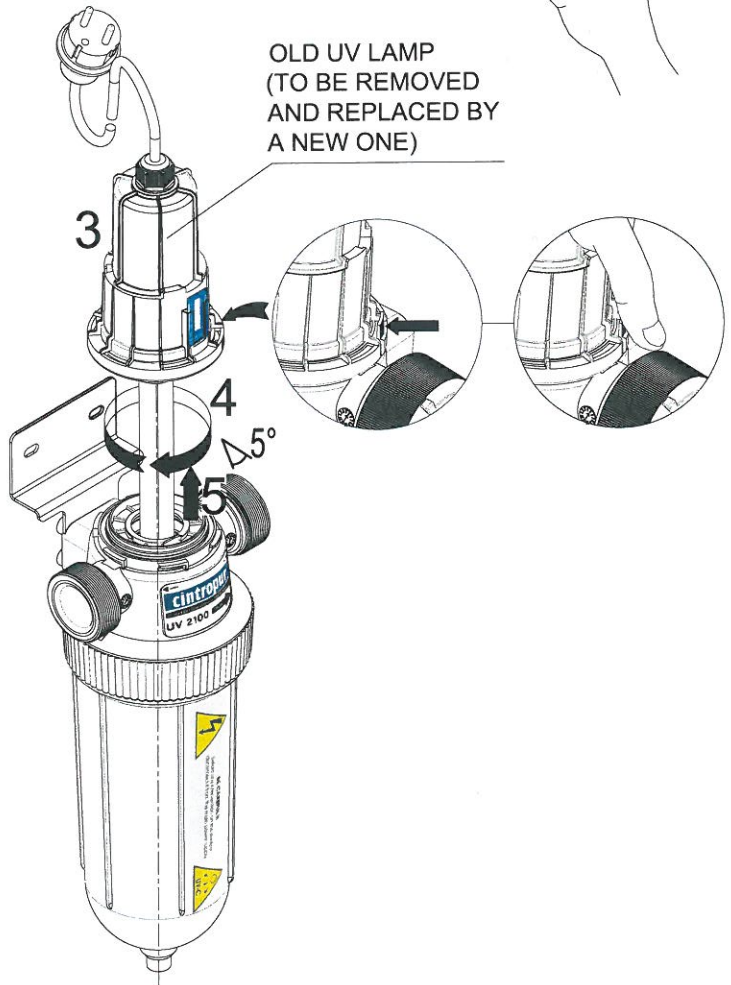

AFTER 5 YEARS OF USE

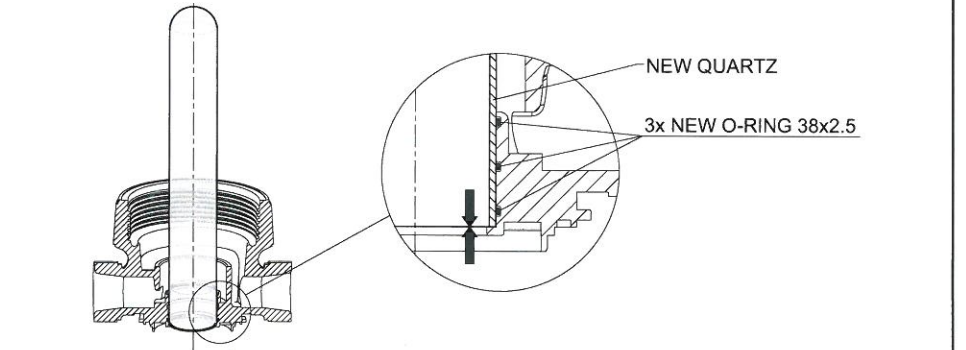
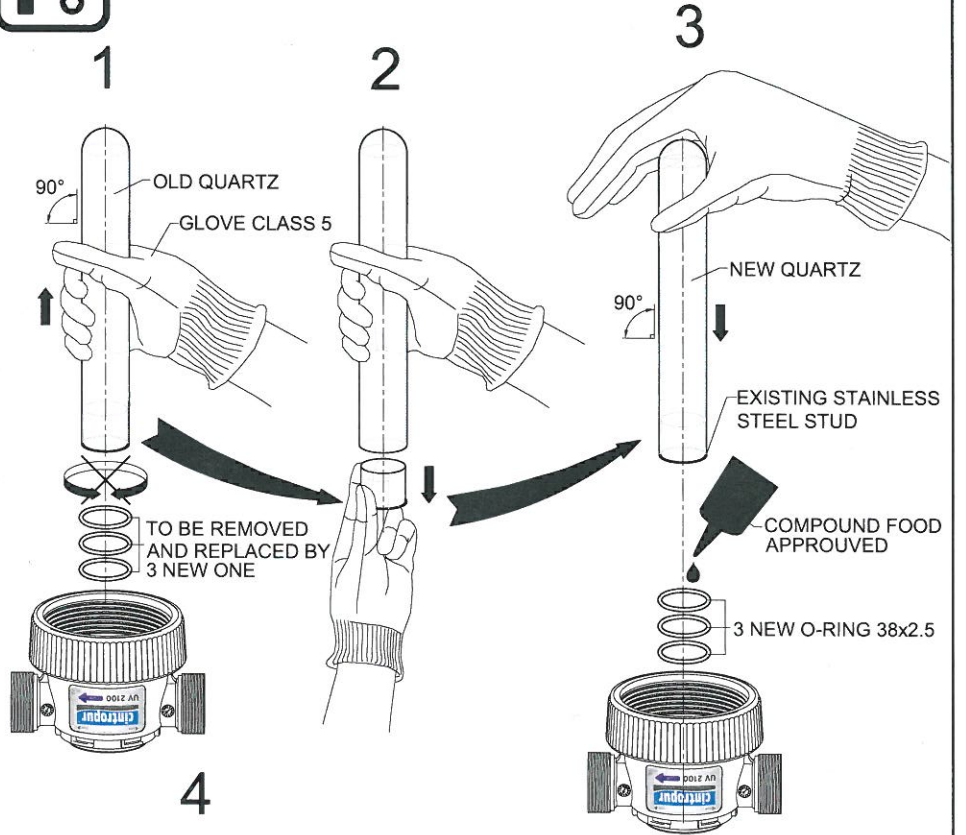

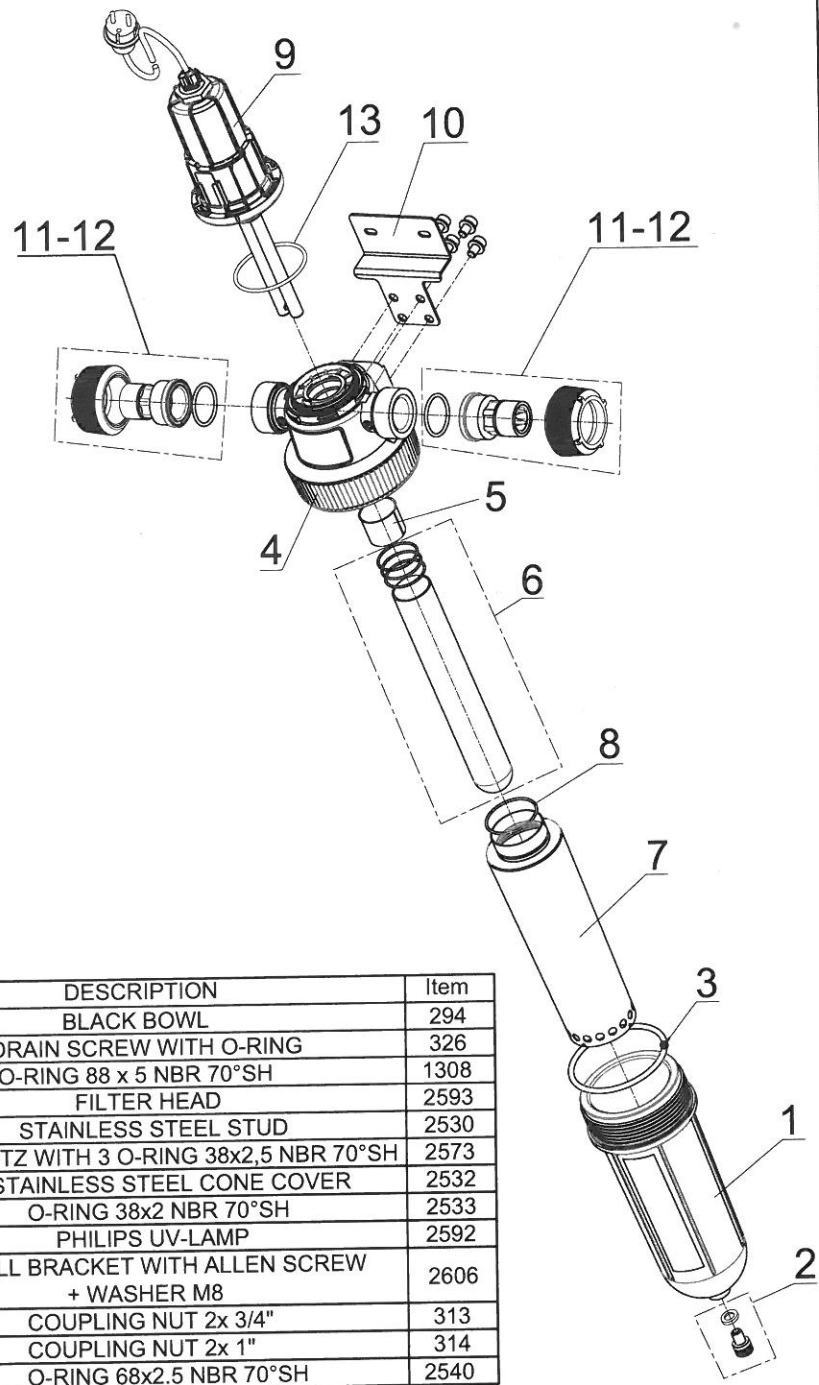

Part #	DESCRIPTION	Item
1	BLACK BOWL	294
2	DRAIN SCREW WITH O-RING	326
3	O-RING 88 x 5 NBR 70°SH	1308
4	FILTER HEAD	2593
5	STAINLESS STEEL STUD	2530
6	QUARTZ WITH 3 O-RING 38x2,5 NBR 70°SH	2573
7	STAINLESS STEEL CONE COVER	2532
8	O-RING 38x2 NBR 70°SH	2533
9	PHILIPS UV-LAMP	2592
10	WALL BRACKET WITH ALLEN SCREW + WASHER M8	2606
11	COUPLING NUT 2x 3/4"	313
12	COUPLING NUT 2x 1"	314
13	O-RING 68x2.5 NBR 70°SH	2540