



Features

- 100% oil free
- 100% duty cycle
- Compact and easy to use
- Easy maintenance
- Long life, 2 year warranty
- 10,000 hour cup life at 8 bar

Accessories

- Automatic drain for the receiver
- Condensate bottle

Description

- 5µm Air filter
- Pressure regulator included
- Receiver with internal coating and 5 year warranty

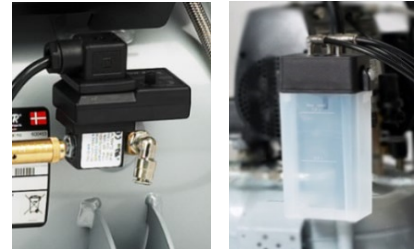

Product Specification

Model	87R-15B			
Voltage	V	1x230	1x230	1x120
Frequency	Hz	50	60	60
Motor	HP	0.5	0.5	0.5
	kW	0.37	0.37	0.37
Displacement	l/min	82	91	91
Air flow @ 8bar	l/min	28	34	34
	cfm	1	1.2	1.2
Max. Pressure	bar	8	8	8
	psi	120	120	120
Max current	A	2.5	2.8	5.7
	Receiver volume	litres	4	4
Weight	gallon	1.05	1.05	1.05
	kg	18	18	18
Weight	lbs	40	40	40
	Noise level	dB(A)/1m	61	61
Duty cycle		100%	100%	100%

Air flow / pressure curve

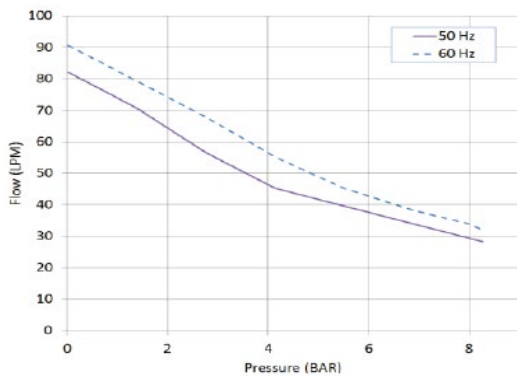

Dimensions - mm [in]*

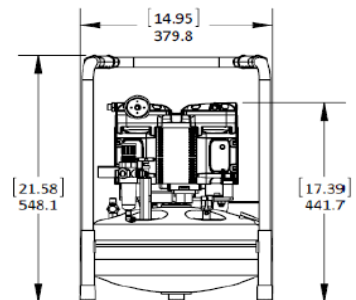
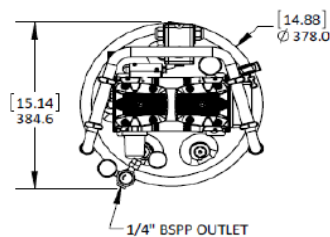

* unit without accessories