



Features

- 100% oil free
- 100% duty cycle
- Compact and easy to use
- Easy maintenance
- Long life, 2 year warranty
- 10,000 hour cup life at 8 bar

Description

- 5µm Air filter
- Pressure regulator included
- Receiver with internal coating and 5 year warranty

Accessories

- Automatic drain for the receiver
- Condensate bottle

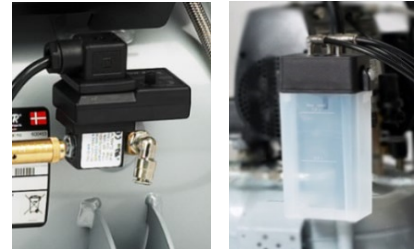

Product Specification

Model	86R-4B			
Voltage	V	1x230	1x230	1x120
Frequency	Hz	50	60	60
Motor	HP	0.33	0.33	0.33
	kW	0.25	0.25	0.25
Displacement	l/min	34	40	40
Air flow @ 8bar	l/min	12.5	15	15
	cfm	0.44	0.53	0.53
Max. Pressure	bar	8	8	8
	psi	120	120	120
Max current	A	1.7	2.1	1.1
	Receiver volume	litres	4	4
Weight	gallon	1.05	1.05	1.05
	kg	15.6	15.6	15.6
Weight	lbs	34.4	34.4	34.4
	Noise level	dB(A)/1m	55	58
Duty cycle		100%	100%	100%

Air flow / pressure curve

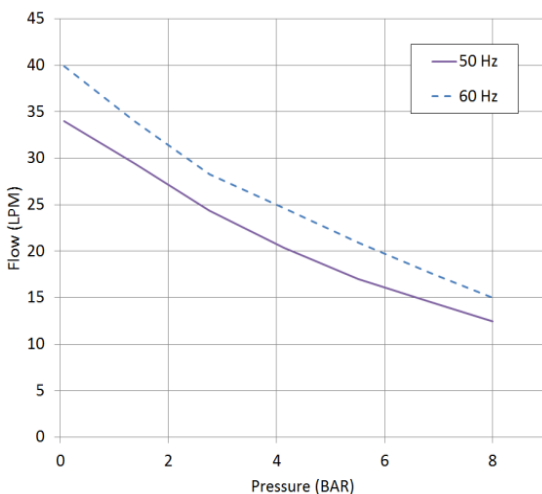

Dimensions - mm [in]*

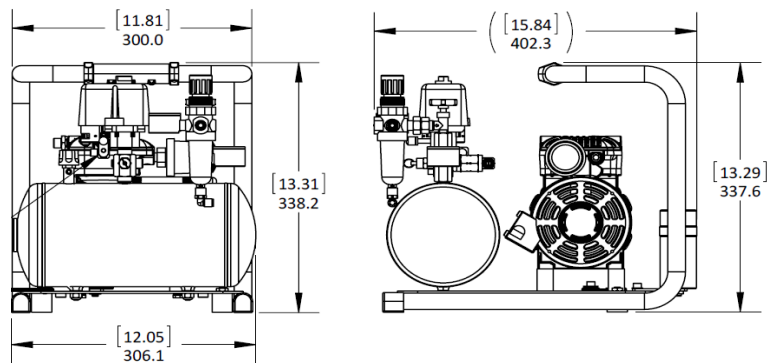

* unit without accessories